

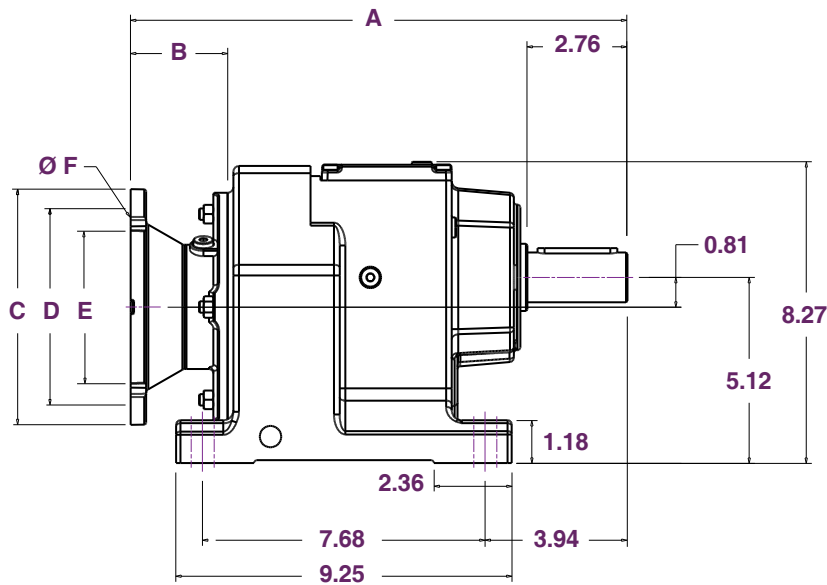

VR68 Dimensions

All dimensions listed in inches



Side

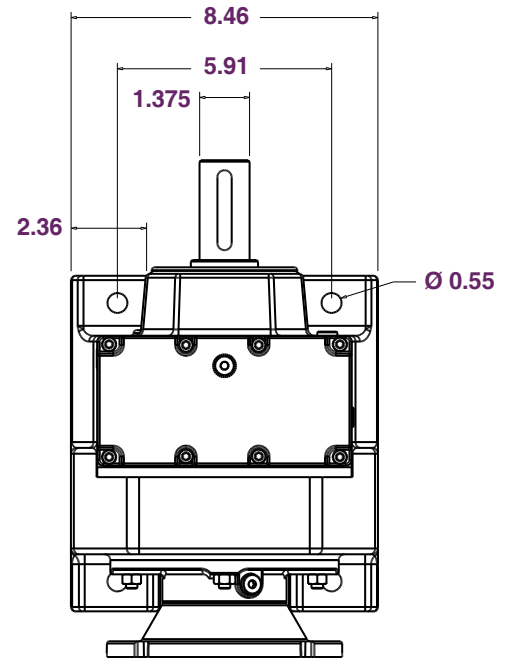

Top

Available Flanges:

Nema Flange Size	A (in)	B (in)	C (in)	D (in)	E (in)	F (in)
56C	13.70	2.68	6.50	5.88	4.500	0.41
140TC	13.58	2.56	6.50	5.88	4.500	0.43
180TC	14.96	3.94	9.00	7.25	8.500	0.59

Motor Options

Nema Frame	Motor Shaft Dia. (in)
56C	0.625
143TC	0.875
145TC	0.875
182TC	1.125
184TC	1.125

Efficiency

Reduction Stages	Efficiency (%)
2	96
3	94

Specifications

Output Key Width (in)	Est. Oil* (oz)	Approx. Dry Reducer Weight* (lbs)
0.3125	37.20	55.12

NOTE: *Oil estimation assumes standard mounting position "A". See page 55 for more information on specific oil amounts in various mounting positions.

*Reducer weights are approximate and can vary by several pounds depending on flange and ratio options.

Ø = common engineering symbol for "diameter".

VR68 Specifications

Stock VR68 Specifications:

Input Speed: 1750 RPM

Service Factor: 1.0

Nominal Ratio	Actual Ratio (:1)	Output Speed (RPM)	Input Power (HP)	Output Power (HP)	Output Torque (in-lbs)	Reduction Stages
40	39.88	43.88	3.80	3.57	5,133.4	3
30	28.13	62.21	4.91	4.72	4,779.4	2
20	19.89	87.98	7.72	7.41	5,310.4	2
15	14.91	117.37	9.44	9.07	4,867.9	2
10	10.00	175.00	12.03	11.55	4,159.8	2

Special Order VR68 Specifications:

Input Speed: 1750 RPM

Service Factor: 1.0

Actual Ratio (:1)	Output Speed (RPM)	Input Power (HP)	Output Power (HP)	Output Torque (in-lbs)	Reduction Stages
199.81	8.76	0.78	0.74	5,310.4	3
184.07	9.51	0.85	0.80	5,310.4	3
158.14	11.07	0.99	0.93	5,310.4	3
137.67	12.71	1.14	1.07	5,310.4	3
128.97	13.57	1.21	1.14	5,310.4	3
113.94	15.36	1.37	1.29	5,310.4	3
105.83	16.54	1.48	1.39	5,310.4	3
95.91	18.25	1.63	1.54	5,310.4	3
86.11	20.32	1.82	1.71	5,310.4	3
74.17	23.59	2.11	1.99	5,310.4	3
69.75	25.09	2.25	2.11	5,310.4	3
61.26	28.57	2.56	2.41	5,310.4	3
56.89	30.76	2.75	2.59	5,310.4	3
51.56	33.94	3.04	2.86	5,310.4	3
46.29	37.81	3.38	3.19	5,310.4	3
37.50	46.67	3.97	3.74	5,044.9	3
32.27	54.23	4.37	4.11	4,779.4	3
26.72	65.49	5.17	4.97	4,779.4	2
23.44	74.66	6.11	5.87	4,956.4	2
17.95	97.49	8.41	8.08	5,221.9	2
15.79	110.83	9.08	8.72	4,956.4	2
12.70	137.80	10.48	10.06	4,602.4	2
11.54	151.65	11.09	10.65	4,425.4	2
8.70	201.15	12.94	12.43	3,894.3	2
7.79	224.65	12.48	11.99	3,363.3	2
7.36	237.77	12.86	12.35	3,274.8	2
6.27	279.11	13.47	12.93	2,920.7	2
5.70	307.02	13.92	13.37	2,743.7	2
4.93	354.97	15.05	14.46	2,566.7	2
4.29	407.93	16.10	15.47	2,389.7	2

